

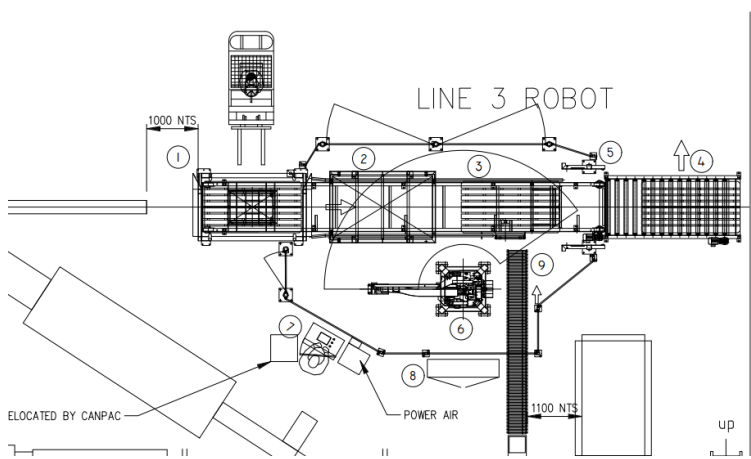

# INTRODUCING DE-PALLETISING & PALLETISING ROBOTS

WE HAVE A COMPLETE PALLETISER & DE-PALLETISER LINE AND ALL EQUIPMENT ASSOCIATED WITH ROBOTS



**TYPICAL ARRANGEMENT**



## De-Palletising & Palletising Systems with Robotic Automation.

The De-palletizer & Palletizer Systems can be supplied as originally designed and constructed, complete with its original Kawasaki Robot, or potentially the pallet handling systems could be purchased as a standalone system for a new robot to be integrated into.

### INCLUDES:

1. Pallet Infeed
2. Bag Outfeed Conveyor
3. Empty Pallet Collating
4. Screen And Safety System



## PALLETISING ROBOT



- **MODEL NO:** ZD130S D
- **SERIAL NO:** ZD1300832
- **MANUFACTURED:** 2006

## DE-PALLETISER MACHINE



- **YEAR OF MANUFACTURE:** 2004
- **KAWASAKI ROBOT YEAR OF MANUFACTURER:** 2005
- **DE-PALLETISING MACHINE CONTROL CONSOLE MOTOR CONTROL CABINET.**

## PACKING ROBOT



- **REPEATABILITY:** 0.4 MM
- **MAX LOAD:** 120 KG
- **MAX REACH:** 2400 MM
- **CONTROLLER:** M96
- **USED TO STACK 6 X 20 KG BOXES**

## D. INDUSTRIAL ROBOT



- **MANUFACTURER:** KAWASAKI
- **MODEL:** ZD130S  
USED TO PACK BOXES (20KG ONTO PALLETS)
- **CAN OPERATE LOAD OF 130 KG**

**AN ASSORTMENT OF MANUALS IS READILY AVAILABLE**

Please register your interest and enquiries to