

Peeling, Preparing, Cutting

# Robot Avocado Line

A robot-assisted, automatic system for pitting, halving and peeling avocado and various types of fruit: for maximum reliability and hygiene, flexible use, capacity planning, very gentle processing and high product quality

**up to 1,000 pieces/hour** Capacity

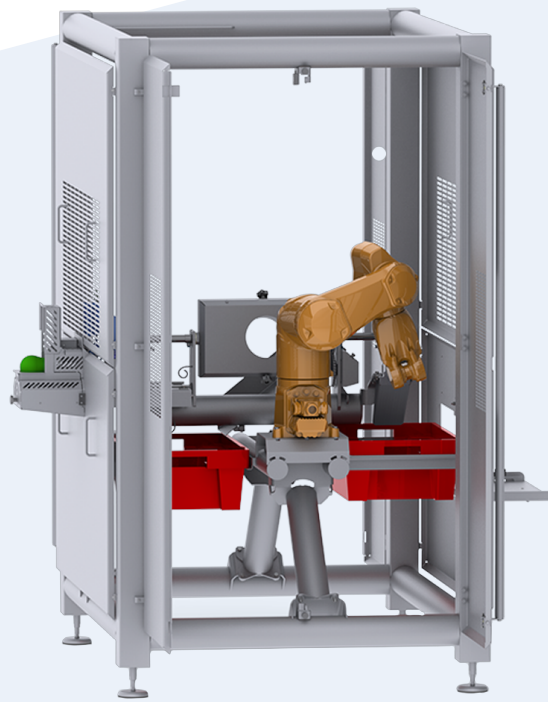

## Your benefits

- ✔ Automated processing for maximum reliability, hygiene, flexibility and planning ability in production
- ✔ Very gentle processing and very high, constant product quality
- ✔ The system can be equipped with one to three robots depending on the desired capacity
- ✔ Tools are integrated that have been specially developed for processing the delicate avocado
- ✔ Maximum, constant yield ratio – the fruit flesh is fully utilized
- ✔ Optional: the avocado can be cut into cubes or slices with a cutting machine.

## Product groups



## Portrait

### **Perfect avocados: absolutely reliable, hygienic and efficient pitting, halving and peeling – up to 1,000 pieces/hour**

A special robotics solution was developed for the automated avocado processing line. It is used for peeling, halving and pitting avocados gently and efficiently at the same time.

The avocados are placed in an inlay tray by an employee. The individual processing steps are then carried out fully automatically by the robot(s):

- The robot removes the avocado with a gripper specially adapted to the fruit and pits the first half by means of a rotating movement on a

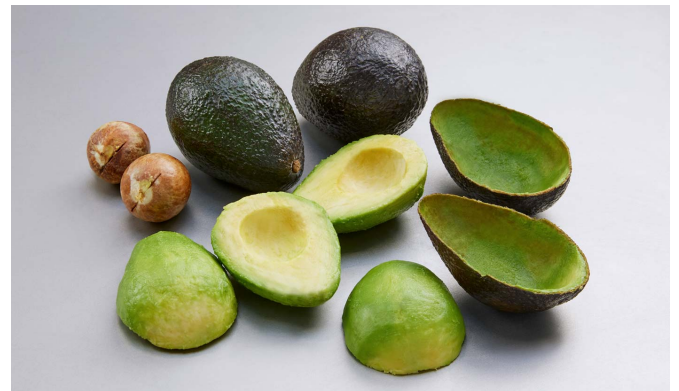

pitting unit.

- The knives cut the flesh in half and clamp the stone.
- The avocado is then peeled. The robot separates the shell from the pulp by moving over the peeling knife.

In the system with a robot, the second avocado half is now pitted and also peeled. Then the cycle starts all over again. At the exit point, another person checks for shell and stone residues as well as natural damage to the product. Good products can be collected in boxes or discharged via a belt, depending on capacity and customer requirements.

Optionally, a **GS 10-2 belt cutting machine** can be added to the line to further process the avocados into cubes or slices.

#### **Benefits of the robotics solution:**

- High reliability
- Temperature independence
- Maximum hygiene
- Flexible use
- Ability to plan capacities

Stäubli robots are integrated, which can be optimally cleaned thanks to the specially treated surface. The system is separated by a safety enclosure. Each KRONEN robotics solution receives its own risk assessment with a CE marking before delivery. This ensures that the facilities optimally guarantee the safety of the personnel.

KRONEN' s robotic systems also feature the option of remote maintenance. This means that the customer can be supported directly and quickly by the KRONEN Service Team if required.

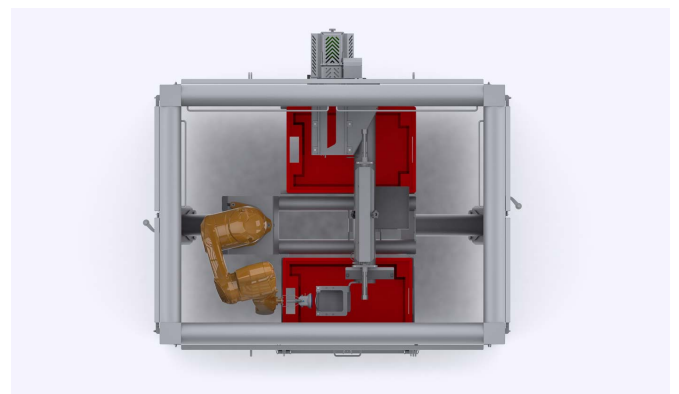

## Application options and capacities:

The system is designed for processing avocados but can be adapted to process various types of fruit, which can be processed with a robot, in the middle segment if required.

Depending on the capacity required, several robots can be used simultaneously:

- up to 400 pieces/hour with one robot
- up to 800 pieces/hour with two robots
- up to 1000 pieces/hour with three robots
- Any amount of further extension possible

To be suitable for processing, the avocados must have a degree of ripeness that corresponds with a pressure value of 0.2 N/mm<sup>2</sup> to 0.8N/mm<sup>2</sup> (hardness measured with a penetrometer).



## Benefits



### Comprehensive project management

The request for a robotics project is first analyzed in the KRONEN project team with regard to the requirements. Subsequently, an installation plan with an idea for implementation and an initial cost framework is drawn up. KRONEN also prepares an ROI calculation or advises the customer on the preparation of a cost-benefit calculation. In the field of robotics, KRONEN is currently focusing on Western Europe: proximity to the customer is an essential component of a partnership in robotics, and this focus means that the KRONEN project team based in Germany can commission the system and provide direct support if servicing is required.

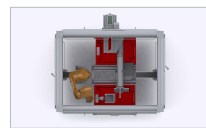

### Maximum hygiene, planning ability and flexibility

One advantage of the automated solution is the reliability of the robot, which remains unaffected by even cold temperature ranges, thus minimizing the risk of failure. The robot can also be easily cleaned and decontaminated, enabling maximum hygiene in the processing facility. It can additionally be used for any length of time – flexibly and as required – and processes a fixed amount of fruit that can be planned in advance during operation.



### Perfect avocados in large quantities

With the system, large quantities of avocados can be processed in the shortest possible time and with maximum care. The delicate fruit is turned into a visually appealing product comparable to the result of manual processing. The surface of the fruit flesh is even smoother when peeling with the peeling tool than when peeling with a knife, spoon or similar conventional tools.



### Maximum yield

The pitting and peeling process is designed to make full use of the fruit flesh, leaving only the minimum amount of waste. For avocado fruit, the yield ratio is approx. 55 percent.



### High-quality robotic technology from Stäubli

Stäubli robots with a coating are used in the industrial system. These robots are specially developed for food processing and meet the highest cleaning and hygiene standards .



### Complete solutions from a single source

KRONEN is a reliable partner, even when it comes to implementing automated processing lines. With a high level of planning and consulting expertise, the company implements the right solution for every customer requirement. KRONEN offers complete lines from a single source and integrates suitable machines from partners as required.

### Made-to-measure solutions



### SMART Solutions for intelligent, networked production

With the SMART option, KRONEN makes communication-enabled machines and processing lines possible. Wherever production managers, technicians or foremen might be, they can check the production status of the machine or line on their laptop or mobile device at any time. The collected data can be used to make production processes even more transparent and efficient, for example in terms of productivity, flexibility, quality and safety. Do you have any special requirements? We can develop an individual, made-to-measure solution for you.

#### SMART Solutions

## Technical data

<b>Electrical power</b>	Power	2 kW
	Voltage	230 V
	Frequency	50 Hz
<b>Air</b>	Working pressure	6 bar
	Air consumption	560 l/min.
<b>Dimensions</b>	LxWxH	1600 x 1670 x 2180 mm
	Weight	675 kg
	Infeed/placement height	935 mm
	Outfeed/delivery height	580 mm
<b>Miscellaneous</b>	Diameter of raw product	55 mm – 80 mm
	Height of raw product	75 mm – 120 mm

